

For more information regarding access, please visit www.ADAchecklist.org

<p>SLOPE</p>	<p>Ramps are required to have one foot of ramp for each inch of rise (ADA 1.27)</p>	<p>1 inch of rise = 12 inches of run = approximate 5° angle</p>	<p>**ALL WOOD SHOULD FOR THE RAMP SHOULD BE PRESSURE TREATED.**</p>
<p>Width of Ramp</p>	<p>42"-48" wide so the inside clear width between mounted handrails is at least 36" (ADA 1.25)</p>	 <p style="text-align: center;">Ramp width</p>	<p>Try to avoid building near roof line; however, if ramp has to be built along roof line, consider snowfall and dripping water which freezes on ramp (gutter installation along ramp?)</p>
<p>NON-SKID SURFACE Ramps should have a non-skid surface - stable, firm and slip resistant (ADA 1.26)</p>	<p>Apply non-skid coating similar to Anvil Paint's Gator Grip. Note: Cold weather options include IKO Ice & Water Shield or AZEK which can be installed in below zero conditions.</p>	<p>Length of Ramp No single run of ramp can exceed 30' unless it has a 4' long, level resting area at its mid-point</p>	<p>SPACE BETWEEN BOARDS ON DECKING OF RAMP ADA compliance: 1/2 inch maximum Between boards</p>

5' x 5' landing at top of ramp

Ramps must have at least a 5' x 5' clear, level landing at the top; flush with entrance door threshold.

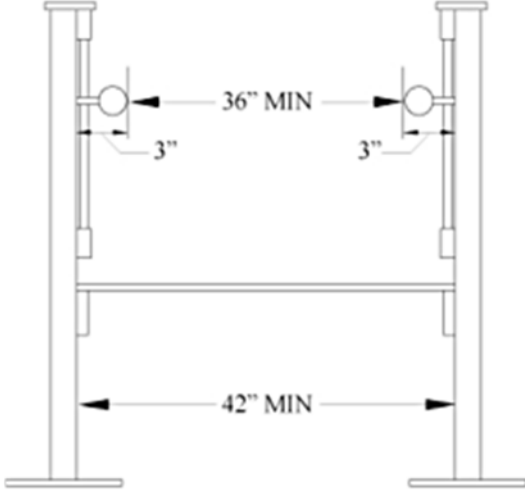

5' x 5' landing at bottom of ramp

Ramps must have a 5' x 5' level, pad at the bottom of the ramp, level with driveway or parking area, so there is a smooth transition from driveway to pad to ramp.

NOTE: Using a product similar to Tractor Supply's 4 ft x 6 ft x 3/4 inch "Thick Rubber Stall Mat" is ok in lieu of poured concrete or blacktop.



4' x 4' vertical posts every 6'-8', both sides of ramp

For stability, ramps must be supported by 4'x4' vertical posts every 6'-8' on both sides of the ramp, as outlined in example to the right:

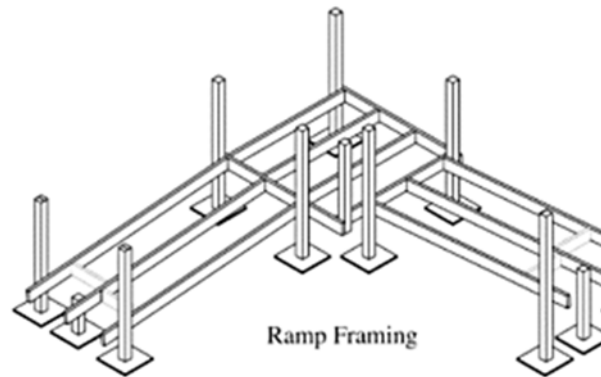

See SKETCH for estimates of how many 4'x4' vertical posts would be needed for this project



- *SONOTUBES for houses
- *DECKING SUPPORTS for rentals and mobile homes

Two 2' x 6' horizontal boards

On each side of the ramp, there should be at least two 2' x 6' horizontal boards attached to the 4' x 4' vertical posts.

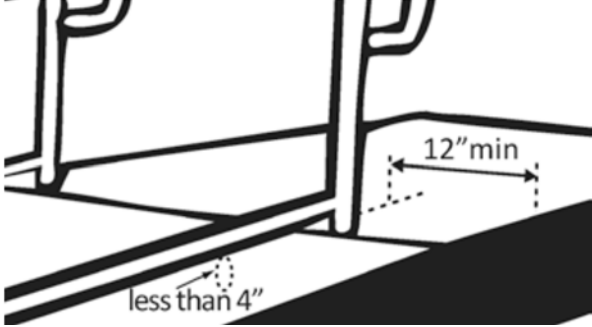
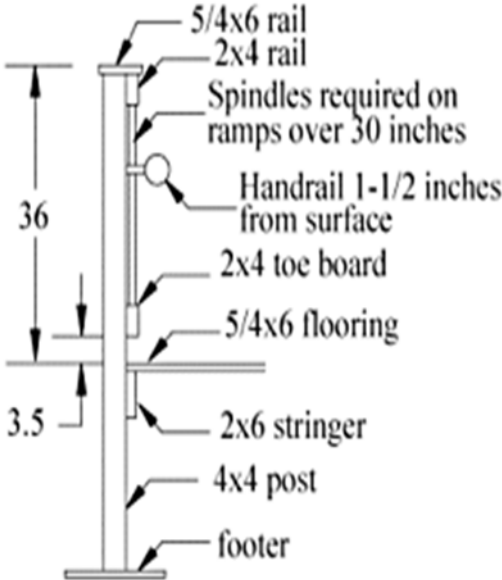
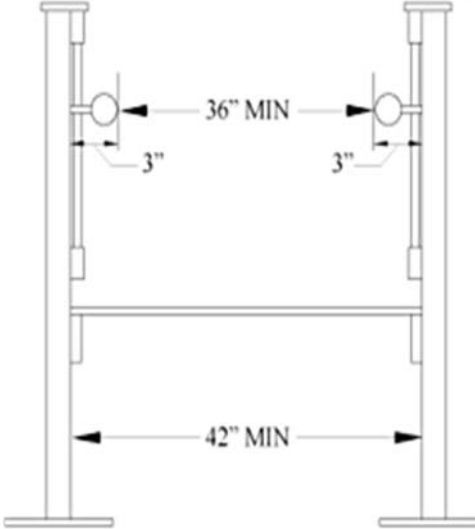

<p>Board 3" above ramp surface</p>	<p>On each side of the ramp and landings (top and middle), there should be a board with its bottom no more than 3" to prevent the smaller front wheels of a wheelchair from going off the edge. (ADA 1.36)</p>		<p>This space should PREVENT a 4" diameter sphere from passing through.</p>
<p>HANDRAILS</p>	<p>Ramps need handrails on each side. Handrails should be:</p> <ul style="list-style-type: none"> *1 ¼"-2" in diameter (ADA 1.33) *Top edge 34"-38" above ramp surface, at height comfortable for peer (ADA 1.31) *Distance between rails (width of ramp) at least 36" (ADA 1.25) *Continuous, free of splinters, and not rotating within their fittings. *Space between handrails and wall of building or sideboard of ramp = 1 ½" (ADA 1.32) 	 <p style="text-align: center;">Post detail</p>	 <p style="text-align: center;">Ramp width</p>

			
<p>MAIN DOOR to the home</p> <p>** EXISTING SCREEN OR STORM DOORS CANNOT BE REPLACED UNLESS APPROVED BY HAP** (Door would swing out, towards ramp.)</p>	<p>Minimum of a 32" clear opening (ADA 1.41)</p> <p>{Note: larger person in larger wheelchair may need larger doorway, ex. 34" or 36"}</p> <p>Lever type hardware with lock, 34"-48" above floor (ADA 1.44, 1.45)</p> <p>Threshold no higher than 1/2", beveled down to 1/4" on each leading edge</p> <p>Door should swing in</p>	<p>ENTRANCE DOOR SHOULD BE INSULATED FIBERGLASS DOOR</p> <p>With lever type lockset</p> <p>Existing screen and/or storm doors cannot be replaced unless approved by HAP prior to the installation</p>	<p>If applicable:</p> <p>Peer wishes to keep these items and NOT have them taken away as part of the normal construction process:</p>
<p>STAIRS</p>	<p>In general, VCIL does not put stairs in with a ramp.</p> <p>In situations where that is necessary, these are the guidelines for steps:</p>	<p>Stair tread (the part you step on) must be a minimum of 11 inches "deep"</p> <p>Stair riser (the distance between one step to the next) must be between 4 inches and 7 inches "high"</p>	<p>Step riser height uniformity (<= 3/8" variation) - this means that more than 3/8 of an inch in variation of the height of steps from one step to another is a tripping hazard</p>

